

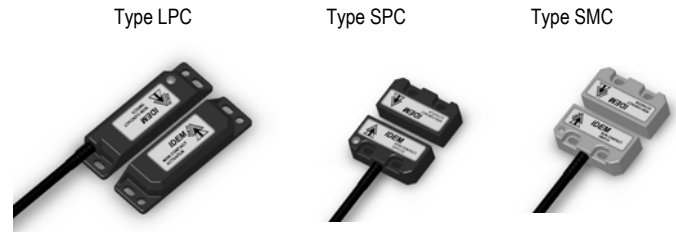

Non Contact Coded Safety Switches from IDEM

Data Sheet Coded Magnetic Series



Using Coded Non Contact Safety Interlock Switches

Application:

IDEM Coded Non Contact switches are designed to interlock hinge, sliding or removal guard doors. They are specifically advantageous when :

- a) poor guard alignment exists
- b) tamperproofing is required
- c) high hygiene requirements exist e.g. food industry hose down
- d) a long mechanical life is required (no moving or touching parts).

When used In combination with approved Dual Channel Safety Modules, IDEM Coded Non Contact Switches can be used to provide up to Category 3 or 4.

Operation:

All IDEM Coded Non Contact Safety Switches are designed to conform to IEC 947-5-3 and be used as directed by EN1088 , EN 292 and EN 60204-1. They have a coded magnetic sensing system which provides a wide (>10mm) sensing distance and provides a high tolerance to misalignment after sensing. They can be fitted behind stainless steel fittings and can operate from 4 directions even in extreme environments of temperature and moisture.

Installation:

Installation of all IDEM Coded Non Contact Switches must be in accordance with a risk assessment for the individual application.

The use of a Safety module is required for monitoring IDEM Coded switches. These controllers monitor 2 redundant circuits as per EN 954-1 for up to Category 4 protection.

M4 mounting bolts must be used to fix the switches. Tightening torque for mounting bolts to ensure reliable fixing is 2 Nm. Always mount on to Non Ferrous materials. The recommended setting gap is 5mm. The Safety switch must not be used as a mechanical stop or be adjusted by striking with a hammer. The actuator must not be allowed to strike the switch. Do not mount adjacent switches or actuators closer than 30mm.

Typical misalignment tolerance after setting is 5mm in any plane.

After installation always check each switch function by opening and closing each guard individually in turn and ensuring that the Green LED on the switch and the LED's on the Safety Modules are illuminated when the switch is closed and are extinguished when the switch is open. Check that the machine stops and cannot be re-started when each switch is open.

Actuator operating directions : Align actuator and switch using the target arrows.

Types SM SP

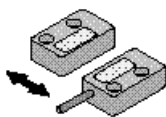

Type LP

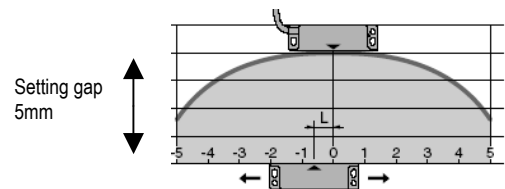
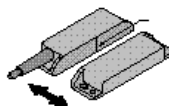

5mm misalignment tolerance after setting

Maintenance:

Monthly: Check alignment of actuator and look for signs of mechanical damage to the switch casing. Check wiring for signs of damage.

Every 6 months: Check each switch function by opening and closing each guard individually in turn and ensuring that the Green LED on the switch and the LED's on the Safety Modules are illuminated when the switch is closed and are extinguished when the switch is open. Check that the machine stops and cannot be re-started when each switch is open.

Never repair any switch, actuator or integral cables. Replace any switch which displays signs of mechanical damage to casing or cables.

Non Contact Coded Safety Switches from IDEM

SP/SM

LP

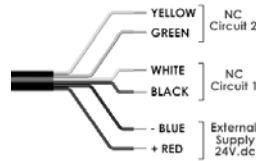
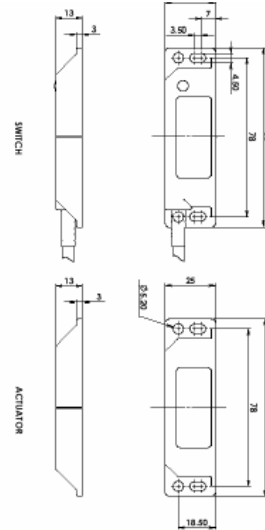
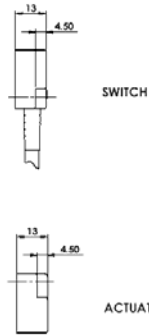
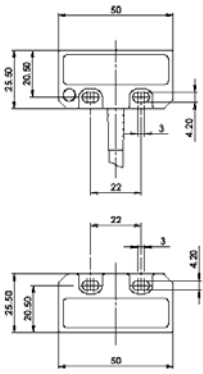

Wiring Examples:

PDF-M IEC 947-5-3

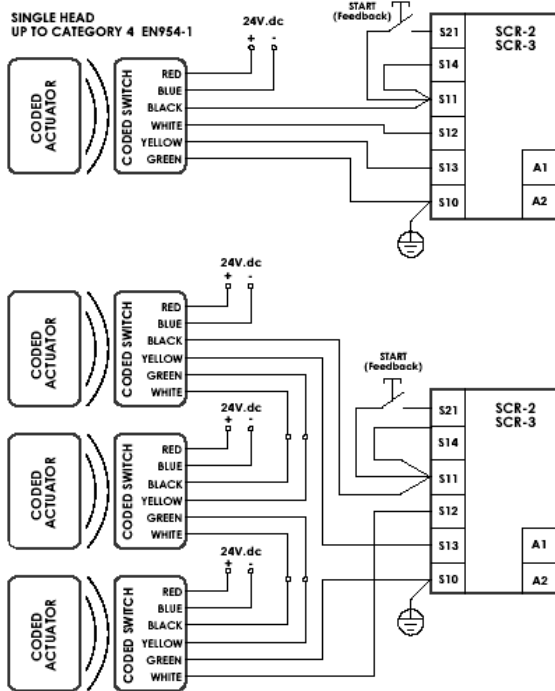

MULTIPLE HEADS (up to 4 Maximum)
UP TO CATEGORY 3 EN954-1

Standards EN1088 IEC 947-5-3 EN 60204-1
EN 954-1 UL508

- Safety Channel 1 NC
- Safety Channel 2 NC
- Safety Channel 3 NO
- Power supply (regulated) 24V.d.c +/-15% Max.Consumption 50mA
- Contact release time <2ms
- Initial contact resistance <500 milliohm
- Minimum switched current 10V. dc 10mA
- Insulation Resistance 100 Mohms
- Dielectric withstand 250V.ac
- Recommended setting gap 5mm
- Switching Distance: Sao 10mm Close (Target to target) Sar 22mm Open
- Tolerance to misalignment 5mm in any direction from 5mm setting gap
- Switching frequency 1.0 Hz maximum
- Approach speed 200mm/m. to 1000mm/s.
- Body Material Red Polyester or Stainless Steel 316
- Temperature Range -25 / 80C. (105C. Stainless Steel)
- Enclosure Protection IP67
- Shock Resistance IEC 68-2-27 11ms 30g
- Vibration Resistance IEC 68-2-6 10-55 Hz. 1mm
- Mechanical Life Expectancy 10,000,000 switchings
- Electrical Life Expectancy 1,000,000 switchings
- De-rating Safety Factor 2
- Tested to 2,000,000 cycles at 24V. 0.2A.
- Cable Type PVC 6 core 6mm O.D. for 2NC
8 core 6mm O.D. for 2NC 1NO
- Mounting Bolts 2 x M4 recommended
- Tightening torque 0.8Nm
- Mounting Position Any

Sales Number		Cable	Circuits
111001	SPC	2M	2NC
111002	SPC	5M	2NC
111003	SPC	10M	2NC
111004	SPC	QD-M12	2NC
111005	SPC	2M	2NC 1NO
111006	SPC	5M	2NC 1NO
111007	SPC	10M	2NC 1NO
111008	SPC	QD-M12	2NC 1NO

Sales Number		Cable	Circuits
139001	SMC	2M	2NC
139002	SMC	5M	2NC
139003	SMC	10M	2NC
139004	SMC	QD-M12	2NC
139005	SMC	2M	2NC 1NO
139006	SMC	5M	2NC 1NO
139007	SMC	10M	2NC 1NO
139008	SMC	QD-M12	2NC 1NO

Sales Number		Cable	Circuits
110001	LPC	2M	2NC
110002	LPC	5M	2NC
110003	LPC	10M	2NC
110004	LPC	QD-M12	2NC
110005	LPC	2M	2NC 1NO
110006	LPC	5M	2NC 1NO
110007	LPC	10M	2NC 1NO
110008	LPC	QD-M12	2NC 1NO

CE Declaration of Conformity.

These Products conform to the Essential Health and Safety Requirements of the European Machinery Directive (98/37/EC) and the Essential Protection Requirements of the EMC Directive (89/336/EEC).

Supplied under RoHS Directive 02/95/EC.

IDEM SAFETY SWITCHES LIMITED,
Unit E9, Moss Industrial Estate, St. Helens Road, Leigh,
Lancashire, WN7 3PT
UK. Tel: +44 (0)1942 261000 Fax: +44 (0)1942 676293

www.idemsafety.com

Nov 06